

THE NEW VALUE FRONTIER



JCT Series
Coolant-through Cut-off Holders

KGD-JCT
for Small Parts Machining

JCT Series Coolant-through Cut-off Holders

KGD-JCT

for Small Parts Machining

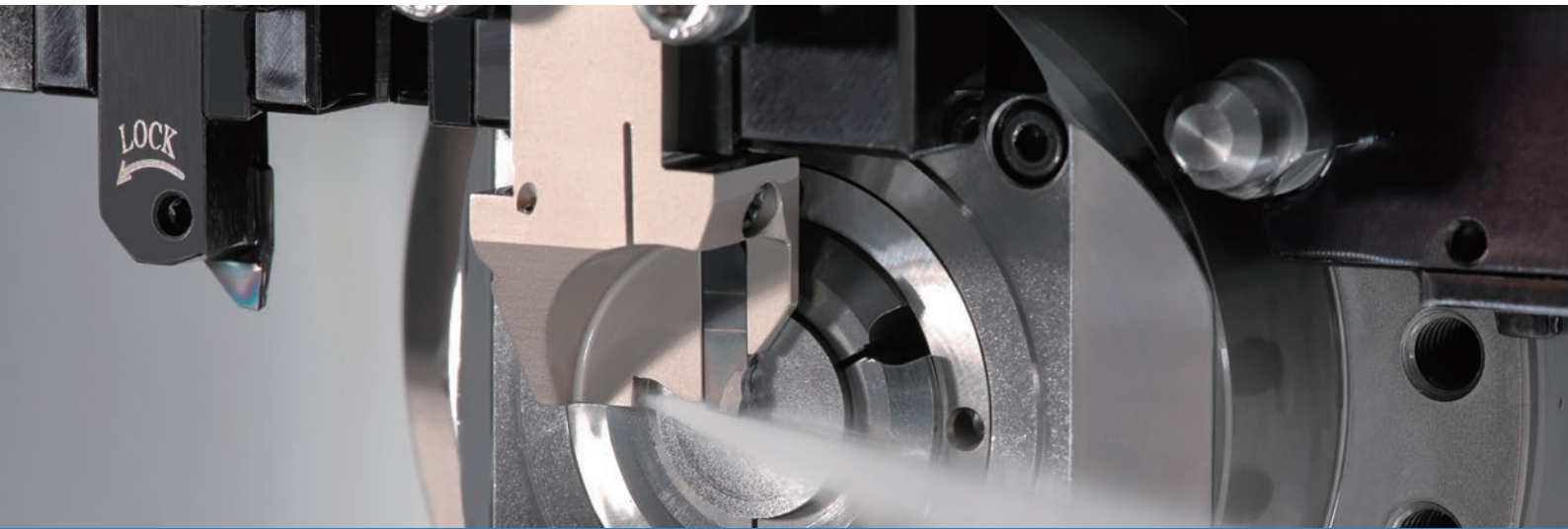

Cut-off Holders for High Pressure Coolant with Long Tool Life

JCT Series for Small Parts Machining
KGD-JCT Cut-off Holder Lineup Expansion
Improved Tool Life Lowers Machining Costs

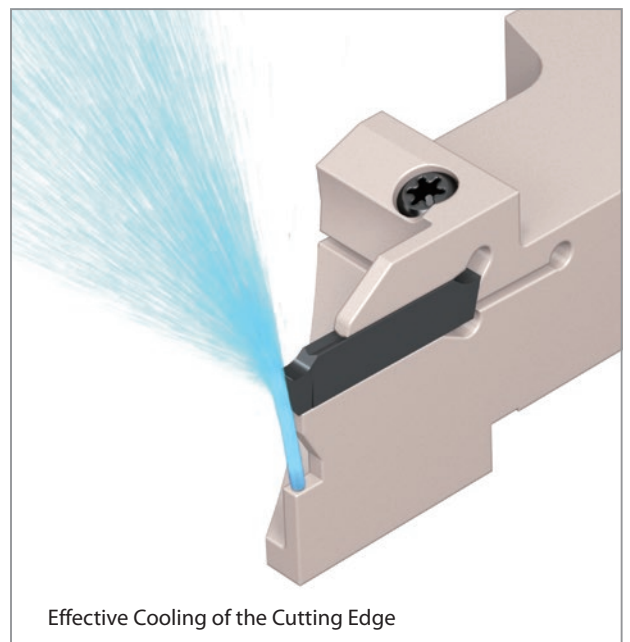

Effective Cooling of the Cutting Edge

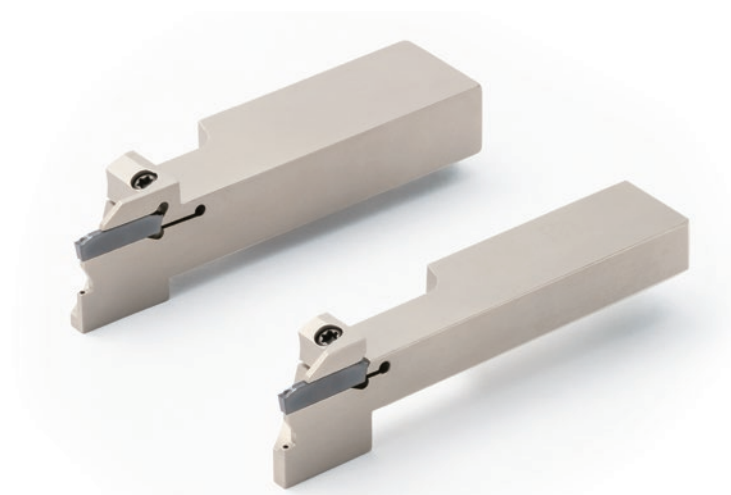

1 Optimized Coolant Hole Position

2 Discharge Coolant towards the Flank Face of the Insert

Coolant Discharging (Image)

KGD-JCT

Sufficient cooling towards the cutting edge

Competitor A

Coolant does not flow directly towards the cutting edge

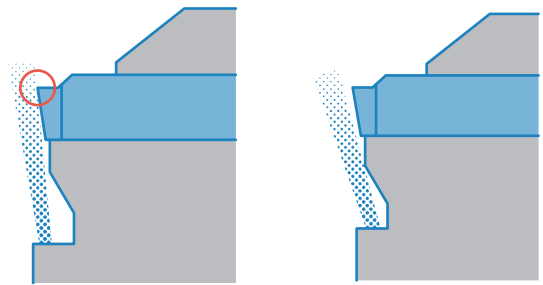

Wear Resistance Comparison

(Internal Evaluation)

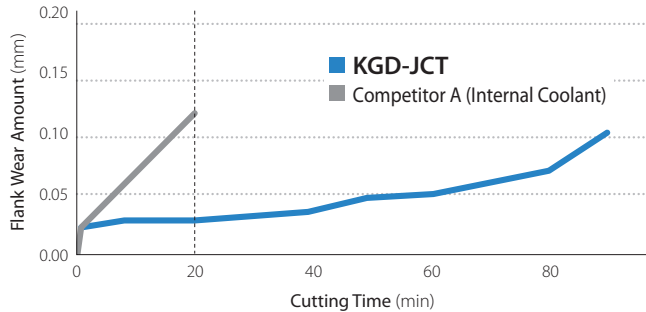

Cutting Conditions : Vc=80m/min, f=0.06mm/rev (~2mm : f=0.02mm/rev), KGDR1625H-2JCT, GDM2020N-015PF PR1535 (Insert Width : 2.0mm) Workpiece : SUS304 (φ25) Internal Coolant(1.5MPa) Cut-off

Cutting Edge (After Machining 20 min)



High density and high speeds coolant provides effective cooling of the cutting edge

Superior cooling action improves tool life

KGD-JCT for Small Parts Machining

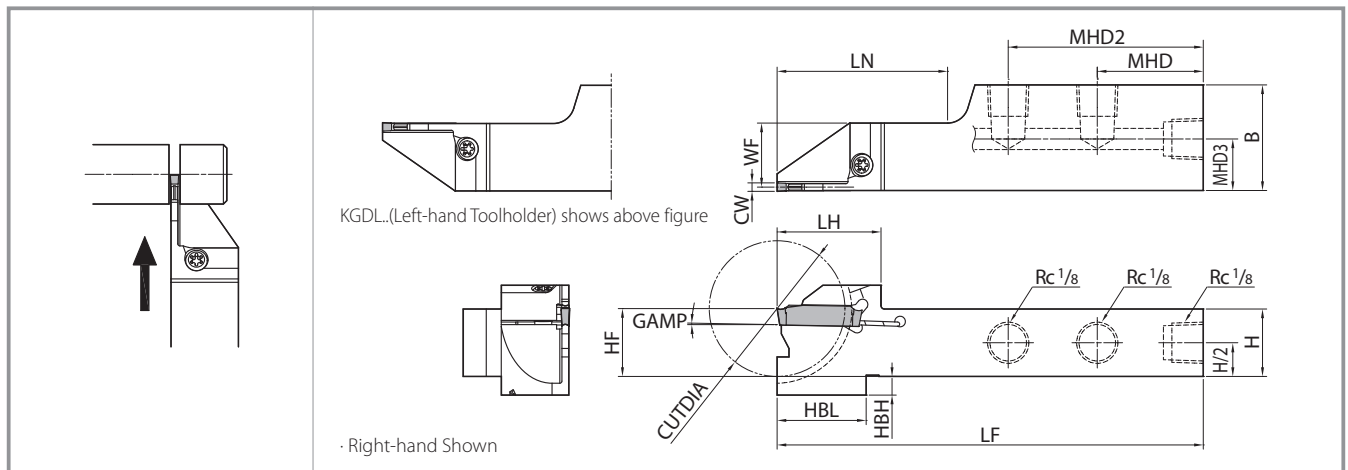

Description	Stock	Cut-Off Dia. CUTDIA	Dimensions (mm)											Angle	Insert Width CW (mm)		Applicable Inserts
			H=HF	HBH	B	LF	LH	HL	LN	WF	MHD	MHD2	MHD3		MIN.	MAX.	
KGDR 1220H-2JCT	●	24	12	8.5	20	100	19.5	21	44	11.2	35	-	8.4	1°	2.0	3.0	GDM Type GDG Type (GDMS Type) (GDGS Type)
KGDL 1220H-2JCT	●							21.5									
KGDR 1625H-2JCT	●	32	16	4.5	25	100	24.5	21	40	15.2	25	46	12.2	1°	2.4	3.0	
KGDL 1625H-2JCT	●																
KGDR 1220H-2.4JCT	●	24	12	8.5	20	100	19.5	21	44	11	35	-	8.4	1°	2.4	3.0	
KGDL 1220H-2.4JCT	●																
KGDR 1625H-2.4JCT	●	32	16	4.5	25	100	24.5	21	40	15	25	46	12.2	1°	3.0	4.0	
KGDL 1625H-2.4JCT	●																
KGDR 1220H-3JCT	●	24	12	8.5	20	100	19.5	21	44	10.8	35	-	8.6	1°	3.0	4.0	
KGDL 1220H-3JCT	●																
KGDR 1625H-3JCT	●	32	16	4.5	25	100	24.5	21	40	14.8	25	46	12.2	1°	3.0	4.0	
KGDL 1625H-3JCT	●																7.7

● : Standard Stock

Spare Parts	Clamp Screw		Wrench		Plug	
		SB-40120TR		LTW-15S		GP-1

For more details on cutting conditions, applicable inserts or piping parts, see the KYOCERA general product catalog or the JCT Series for small parts machining brochure